

SWARCO

SW2224

LOOP DETECTOR

VEHICLE CLASSIFICATION AND SPEED MEASUREMENT

SWARCO loop detector for vehicles detection with classification and speed measurement for traffic data acquisition and traffic management.

SW2224 CLASSIFICATION DETECTOR

The SW2224 operates with two induction loops per lane, in accordance with ASTRA-SWISS specification. Based on the proven and tested MC2024 / CD9054, the detector uses state-of-the-art measurement methods for highest classification accuracy and detection speed.

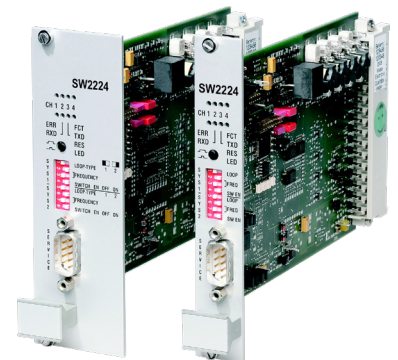

FEATURES

- Acquisition of traffic data in accordance with ASTRA¹ for two lanes with speed and length measurement, detection of direction and wrong way drivers with double loop systems, occupancy rate in connection with a controller
- Serial data transfer via interface
- 4 Open collector switching outputs for detection signals or optional functions
- Switching signals depending on vehicle class and/or vehicle speed for the direct control of a VMS with parameterizable blinking frequency and number of light impulses (special version)
- Single-loop version for traffic data acquisition and vehicle classification with single loops² for 4 lanes (special version)
- Maintenance-free
- Low power consumption
- Highly-reliable data acquisition, absolutely independent of climatic conditions and insensitive to interferences
- Automatic alignment, regulation of temperature fluctuations and non-volatile storage of all operating data
- For feed cable lengths up to 300 m with ASTRA-SWISS loops only one pair of wires per loop necessary
- Easy and space-saving integration due to Euro-card format for 19" rack (selectable width: 20 or 40 mm)

¹ ASTRA: Swiss federal roads office

² without speed / length measurement and detection of direction

SW2224 LOOP DETECTOR

FUNCTIONAL DESCRIPTION

The SW2224 classifies the vehicles in ASTRA-SWISS classes (SWISS 10, SSVZ or car-similar/HGV-similar vehicles). When ASTRA-SWISS loops are used, the classification meets the accuracies required by the ASTRA and is not influenced by e.g. weather conditions. On activation of the directional logic, reports of wrong way drivers can be generated. The vehicle type is determined by means of passing-curves which have characteristic features depending on the different classes and the loop types used. The detector can provide the following single-vehicle data via the RS232 service interface and the RS485 data interface:

Single vehicle data:	vehicle class, speed, length, distance, time of occupancy, time gap, driving direction
2 classes:	car-similar vehicles (vehicles < 3.5 t) / HGV-similar vehicles (vehicles > 3.5 t)
SSVZ classes:	motorbike / car (motorbike, car, car with trailer) / van (van, van with trailer, van with semitrailer) / bus, car / HGV / HGV with trailer + HGV articulated
SWISS 10 classes:	motorbike / car / car with trailer / van / van with trailer / van with semitrailer / bus, car / HGV / HGV with trailer / HGV articulated

Via the RS485 bus single-vehicle data is transferred to a controller, which takes over further data aggregation acc. to ASTRA specification. The detector automatically adjusts itself to the attached loop/feed-cable combination. Variations in temperature have no influence on data acquisition. The measuring systems are permanently checked for short or open loops, only when a definite malfunction is detected, systems are put into a failure condition. If one loop of a double-loop system is disturbed, the remaining loop supplies further data on time of occupancy, time gap and a classification of car-similar and HGV-similar vehicles. Speeds and vehicle lengths cannot be determined. Short measuring intervals and a new procedure for speed measurement provide for the high accuracy of the measured data and the high detection speed, according to the requirements of the Swiss federal roads office.

TECHNICAL SPECIFICATIONS

Supply voltage	5 V DC +/-5 % (regulated and load-independent)
Power consumption	max. 90 mA / 0.45 W (5 V DC, standard switching output Open Collector)
Interfaces	RS485 data interface (plug connector), RS232 service interface (on front)
Switching outputs	switching output per channel: Open Collector, common error output: Open Collector optional: electronic relay contact
Dimensions	height: 128 mm, length: 190 mm, width: 20 mm (4 TE), optional 40 mm (8 TE)
Operating / storage temperature	-25°C to +80°C / -40°C to +80°C
Protection	III (low voltage < 60 V DC)
Design	plug-in card for 19" rack, to be installed in housing or cabinet with IP54 necessary (pollution degree 2)
Terminal strip	DIN 41612, type F: 48-pole strip, 3-row

For detailed information about the function, operation and pin assignment as well as further technical data see user manual.

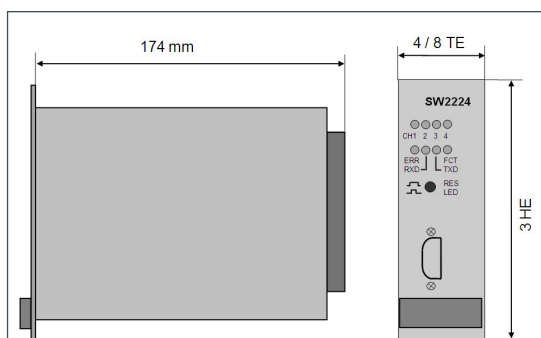

Dimensions

