

SW3224

LOOP DETECTOR
WITH ASTRA-SWISS-SPECIFICATION

SW3224_BE_10



Content

1	Introduction	4
1.1	About this manual.....	4
1.2	Usage according to regulations.....	4
1.3	Label.....	5
1.4	Further documentation.....	5
1.5	Symbols.....	5
1.6	Safety instructions.....	6
2	Product description	7
2.1	General.....	7
2.2	Overview of the essential product characteristics.....	9
3	Installation of the CD3224	10
3.1	Installation and start-up of the unit.....	10
3.2	Overvoltage protection and loop diagnosis.....	11
3.3	Connection of the feeder cable.....	11
3.4	Parameterizing the traffic data acquisition.....	12
3.5	Notes for installation.....	12
4	Operating the CD3224 with LoopMaster	13
4.1	General.....	13
4.2	Functionalities.....	13
5	Display and operating elements at the front panel	15
6	Alignment and error diagnosis	16
6.1	Alignment.....	16
6.2	Error detection and troubleshooting.....	17
6.3	Automatic calibration and control of vehicle detection.....	18
7	Parameters and functionality	21
7.1	Significance of the channel parameters.....	21
7.1.1	Channel function.....	21
7.1.2	Frequency range.....	21
7.1.3	Loop type and loop distance.....	25
7.1.4	Smoothing of measured values.....	25
7.1.5	Vehicle length correction.....	26
7.1.6	Detection of wrong way drivers.....	26
7.1.7	Address data bus.....	27
7.1.8	Sensitivity / measuring time.....	27
7.1.9	Hold time.....	28
7.1.10	Channel flags.....	28
7.1.11	Extended channel flags.....	29
7.1.12	Maximum loop alignment duration.....	29
7.1.13	Noise threshold.....	29

7.2	Significance of the device parameters	30
7.2.1	Language service interface	30
7.2.2	Service interface output functions and baudrate	30
7.2.3	Hardware address data bus	30
7.2.4	Baud rate data bus	31
7.2.5	Detector flags.....	31
7.2.6	LED turn-off time.....	31
7.3	Significance of the channel diagnostic values	32
7.3.1	Loop length	32
7.3.2	Channel status.....	32
7.3.3	Vehicle classification	32
7.3.4	Channel error.....	32
7.3.5	Alignment counter and hold time exceedance	32
7.3.6	Inductance	32
7.3.7	Frequency.....	33
7.3.8	Turn-on threshold, maximum and last amplitude	33
7.3.9	Norm value	33
7.3.10	Alignment cause	33
7.4	Significance of the device diagnostic values	34
7.4.1	Reset counter, reset cause.....	34
7.4.2	Cycle time	34
7.5	Description of the special functions	35
7.5.1	Synchronization	35
7.5.2	Notes concerning the data bus function	36
8	Appendix	37
8.1	Technical data	37
8.2	Dimensions and housing layout	39
8.3	Mounting and dismounting	39
8.4	Pin assignment	40
8.4.1	Overvoltage protection of inductive loops	40
8.4.2	Connection terminals on top and bottom side	40
8.4.3	DIN-rail bus system TBUS.....	41
8.4.4	Pin assignment service interface (3.5 mm stereo jack plug, TRS).....	42
8.5	Requirements for the usage according to regulations.....	43
8.6	EC Conformity	44

1 Introduction

In this chapter you will find preliminary remarks about the usage of the SW3224, as well as explanations about the structure of this manual and the usage of symbols.

1.1 About this manual

On the following pages you will learn how to install and operate the device in an appropriate way.

We attach great importance to the safe, appropriate and effective handling of this device. It is therefore important to read this manual thoroughly before using the device. In the manual you will find important instructions helping you to avoid danger and to prolong the reliability and durability of the device and the accessories.

For your own safety you should read the safety instructions. Follow the instructions closely in order to avoid danger for yourself and others or damage to the device.

If you have any questions about the SW3224 which are not answered in this manual, or if you have problems understanding the descriptions, please contact:

SWARCO TRAFFIC SYSTEMS GmbH
Niederkircher Straße 16
54294 Trier
Germany

www.swarco.com

1.2 Usage according to regulations

The SW3224 is solely suited for the detection of vehicles in road traffic. Any further usage is not appropriate. Do not use the SW3224 for any other purpose.



NOTE

The SW3224 is designed for precise vehicle classification and speed measurement in interurban systems for traffic data acquisition and traffic control. It is less suited for urban applications e.g. at traffic light intersections. The conditions for precise vehicle classification such as constant moving are not fulfilled. For these kinds of applications, we recommend using detector types from our traffic lights product folio, e.g. IG746 / IG946 (see www.swarco.com under Products – Detection and Sensors).

For further requirements for the usage according to regulations see chapter 8.5.

1.3 Label

The SW3224 is provided with a quality label and serial number. You will need the indications when talking with the customer service, e. g. ordering accessories or spare parts.

Note here the serial number and name of the device in order to have them available when needed:

Serial number: _____

Device identification: _____

This manual is valid for all classification detectors type SW3224. Documentation of optional functionalities are described in chapter 1.4.

CE-label:



1.4 Further documentation

- "Loop installation TLS", SWARCO TRAFFIC SYSTEMS GmbH
- "VTD – Vendor-specific telegram definitions", SWARCO TRAFFIC SYSTEMS GmbH
- "Technical delivery terms for roadway stations (TLS)", BASt (German federal highway research institute)
- "Optional Speed/Class function for classification detectors", SWARCO TRAFFIC SYSTEMS GmbH
- "Optional Single Loop function for classification detectors", SWARCO TRAFFIC SYSTEMS GmbH
- "Richtlinie Verkehrszähler 13012", ASTRA (Swiss federal roads office)

1.5 Symbols

In several places throughout this manual you will find the following symbols stating important safety instructions:



ATTENTION!

This symbol indicates dangers which might cause damage to people or property



NOTE

This symbol indicates information for installation and function of the device

1.6 Safety instructions

Read the following safety instructions thoroughly and observe them carefully. They are stated to ensure your own safety and the safety of others and to avoid damage to the device or accessories.



ATTENTION!

- **Danger of electricity!**
Make sure that no liquid may get inside the device. If this happens, interrupt the power supply to the device at once.
- If you notice any damage, e.g. broken or crushed cables, damaged plugs, enclosures etc., turn off the device at once, interrupt the power supply and make sure that the device cannot accidentally be turned on again.
- The device may only be installed, brought into service and repaired by an electro-technical expert. Inappropriate operation, improper maintenance or not observing the instructions in this manual can lead to danger.
- Any malfunction of the device which may limit the safety of its users or others must be removed immediately. All warning and safety labels on the device must be observed and kept complete and legible.
- The appropriate usage must be observed by all means. For damage resulting from inappropriate usage the manufacturer will not undertake any liability.
- The device must not be used as a safety component in the sense of the European Directive 2006/42/EC ("Machinery Directive"). In systems with high risk additional safety measures are necessary.
- The operator of the device must ensure that the chosen means of operation will not cause damage to material or danger to people and that all security and safety installations are present and functioning.
- Before installation and first operation please observe the instructions in the manual.
- The manual must be available at the site of usage at any time. It must be read thoroughly and applied appropriately by the person responsible for the operation, maintenance and service of the device.



NOTE

- Our products are in a constant process of improvement and advancement. Because of this, read the current manual thoroughly before installation and first operation.
- Without prior consent of the manufacturer, no modifications, neither mechanical nor electrical, may be done. Only parts that have the consent of the manufacturer may be used for backfitting or as accessories. Any violations will lead to the termination of conformity and the manufacturer's warranty. The user will subsequently bear the risk.

2 Product description

2.1 General



Figure 1: Front view

The SW3224 now offers the functions and outstanding features of the SWARCO TRAFFIC SYSTEMS 19" plug in classification detectors also in a DIN-rail mount version. Based on the proven and tested SW2224, it includes a complete overvoltage protection module for the induction loops. This integration, together with the mounting concept and the compact housing, considerably reduces the wiring effort and required space.

The SW3224 is a classification detector operating with two induction loops per lane according to ASTRA-SWISS-specifications. The usage of powerful 32-Bit controllers allows the improvement of all features such as classification accuracy, power consumption, as well as the function range.

The SW3224 classifies the vehicles into the ASTRA-SWISS-classes (SWISS10, SSVZ vehicle classes or car-similar / HGV-similar). When using ASTRA-SWISS loops, the classification meets the definitions of ASTRA.

The detection quality is not influenced by e.g. the weather. By activating the directional logic, messages for wrong way drivers can be generated.

The vehicle class is determined by means of the detection curves, which show typical features for the different classes and the loop type used.



ATTENTION!

The SW3224 is especially adjusted for ASTRA inductive loops type SWISS10. Only by the use of the correct loop type, the excellent classification accuracy could be achieved.

The detector can provide the following single vehicle data via service interface and RS485 data interface:

Single vehicle data:	vehicle class, speed (up to 300 km/h), length, distance, driving direction
Additionally available at data interface:	Interval occupancy and time gap to calculate the occupancy rate; single-vehicle occupancy and time gap
SWISS10-vehicle classes:	motorbike / car / car with trailer / van / van with trailer / van with semitrailer / bus, car / HGV / HGV with trailer / HGV articulated
	The classification into SSVZ vehicle classes resp. car-similar / HGV-similar vehicles is based on the SWISS10 vehicle classes according to ASTRA guidelines.

Table 1: Data of the SW3224 at the service and data interface

Single vehicle data is transmitted via the RS485-bus to a controller, which carries out the further data-aggregation according to ASTRA-specification.

The detector aligns itself automatically to the loops and feed combination connected. Variations in temperature do not affect the data acquisition. The measurement systems are permanently checked for short-circuited or open loops and only put in an error status when a definite malfunction is recognized. If one loop of the TLS double-loop system is defective, the remaining loop still provides time of occupancy, time gap and a classification of car-similar and lorry-similar vehicles. Speed and vehicle length cannot be detected anymore.

Short measurement intervals and a particular speed measurement processes ensure the high accuracy of measurement data and the high detection speed according to ASTRA requirements.

The detector processes the loops one after the other in a predetermined sequence (multiplex mode); i.e. there is always only one loop switched as inductance L to the LC oscillating circuit of the detector. Since there is always only current flow through one loop, the channels of a detector cannot interfere with each other. The channel reaction times and the cycle time of the detector indicated in the technical data result from the multiplex mode.

If a metallic object is located within the range of action of the connected induction loop, the frequency of the LC oscillator also changes owing to reduction in the loop inductance. The detector evaluation circuit determines these changes and generates e.g. vehicle profiles for the classification.

The detector is configured via service interface on the front. The free PC service software **LoopMaster** provides a convenient operator interface for modifying and displaying all parameters and diagnostic values. The configured parameters are stored in a non-volatile memory (EEPROM).



ATTENTION!

The loop detector SW3224 is solely designed for use by qualified personnel trained in dealing with traffic detection equipment. Improper use of the SW3224 may result in unpredictable behavior of the systems controlled by the detector.

2.2 Overview of the essential product characteristics

- Traffic data acquisition and vehicle classification ASTRA-SWISS according to ASTRA for two lanes
- Measurement of speeds and lengths, detection of direction and wrong way drivers by means of double loop systems, occupancy rate in connection with a controller.
- Data interface: RS485 interface at terminal strip
- Service interface: 3.5 mm TRS socket at the front
- 4 Open Collector switching outputs with parameterizable function: Detection signals or optional functionality for SW3224SP (see below)
- Easy and space-saving integration due to DIN-rail mounting
- Maximum modularity by TBUS system: bus system integrated in DIN-rail for power supply, RS485 interface and detector synchronization
- Complete integrated overvoltage protection for inductive loops, no additional components necessary
- High interference resistance by means of frequency adjustment, smoothing of measured values and detector synchronization (see chapter 7.5.1)
- Loop control in multiplex mode
- Wide setting range for measurement frequency
- Low power consumption
- Convenient operation by means of service software LoopMaster via service interface, saving of unit-specific or application-specific parameter sets by means of LoopMaster
- Non-volatile storage of all operating parameters in EEPROM
- System parameters, e.g. frequency, hold time, loop distance
- Channel diagnosis values, e.g. measurement frequency, loop inductance, failure type
- Permanent loop control for immediate detection of inductive loop failures
- Automatic compensation of temperature influences and ferrite control
- High interference resistance by means of frequency adjustment, oversampling and possibility of detector synchronization
- Automatic alignment after activation, reset or parameter modification
- Automatic recalibration in case of malfunction
- μ -controller with watchdog and power fail monitoring
- Special options:
 - SW3224SL: Traffic data acquisition and vehicle classification with single loops for 4 lanes, without speed and length measurement, no recognition of driving direction and wrong way driver, the excellent classification accuracy of the double loop variant is reduced in the single loop version
 - SW3224SP: switching signals depending on vehicle class resp. vehicle speed and driving direction for the direct control of optical traffic signs with parameterizable blinking frequency and number of pulses

3 Installation of the SW3224

3.1 Installation and start-up of the unit

The SW3224 was designed for DIN-rail mount (TS35 EN50022). Into the DIN-rail a bus system (TBUS) for power supply, a RS485 data interface and a synchronization can be integrated. For further information about DIN-rail mounting see chapter 8.3.

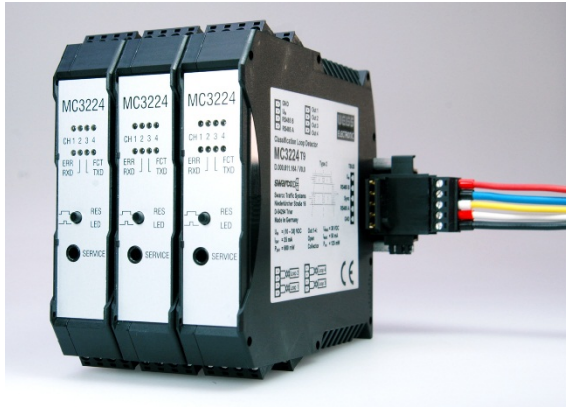

Figure 2: Example: Detector mounted on DIN-rail, including TBUS-bus plug and connector

Wire the device according to the terminal assignment in the appendix (chapter 8.4). Please refer to the technical data for the specification of the supply voltage.



NOTE

When connecting the loops, all feeder cables must be twisted up to the terminal clamps of the MC3224! Do not use the feeder cables parallel to e.g. AC-power supply or communication cables! The loop installation manual by SWARCO TRAFFIC SYSTEMS GMBH must be observed (available on request).



ATTENTION!

When connecting the integrated overvoltage protection of the inductive loops, the DIN-rail must be connected with the protective earth (PE) (see also chapter 8.4.1).



ATTENTION!

Incorrect connection of the unit may result in malfunctions or destruction of the unit. SWARCO TRAFFIC SYSTEMS GMBH does not provide any warranty coverage for unit function in case of incorrect installation and cannot be held liable in this case. The general electro-technical rules must be complied with when connecting the detector.

After switching on the unit for the first time, the detector aligns to the connected loop inductance. Short-circuited or open loop connections are indicated by the **ERR** (ERROR) collective error LED and flashing of the channel LED of the faulty channel (see also chapter 6.2). The **FCT** (FUNCTION) LED flashes during normal operation with a frequency of 1 Hz.

3.2 Overvoltage protection and loop diagnosis

The detector offers a completely integrated overvoltage protection for the inductive loops. No additional components are necessary.

Before the detectors are installed, the loop values must be checked. The values for loop inductance, ohmic resistance and insulation resistance should be checked and documented.

For more information about loop installation see the manual "Loop installation TLS".

3.3 Connection of the feeder cable

For short distances between detector and induction loop up to approx. 20 m, the feeder cable can be directly connected to the feeder clamps. The loop feeder cable must be drilled approx. 10 – 20 times per meter.

For longer distances to the roadside station, we recommend using an outdoor telephone cable type A-2Y (L) 2Y resp. A-2YF (L) 2Y (see also chapter 8.1). Please also observe the according information about loop connection and cable types to be used stated in the TLS.

In order minimize the coupling of channels caused by a shared feeder cable, both channels of a measurement system **must** be connected to the opposing leads of a star quad (e.g. channel 1: 1a – 1b and channel 2: 2a – 2b).

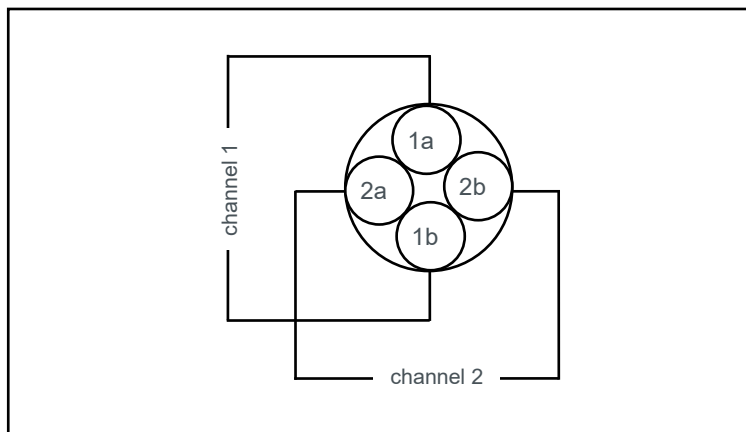

Figure 3: Connection of the inductive loops in a star quad of cable type A-2Y (L) 2Y



NOTE

For feed cable lengths up to 300 m and the indicated cable type only one pair of wires per loop is necessary in the feed cable. No expensive double pair of wires – often impossible in existing systems – is needed.

For feeder cable lengths longer than 300 m up to approx. 500 m, a double pair of wires per loop can also be used (please inquire). Here, a star quad is used per channel. The parallel wiring of 1a / 1b and 2a / 2b reduces the ohmic resistance of the feeder cable by half, the inductance of the feeder cable is reduced to approx. 25 % of the value using one pair of wires.

The connection between the induction loop and the feeder cable must be made by means of a permanently watertight sleeve.

3.4 Parameterizing the traffic data acquisition

In order to parameterizing the traffic data acquisition, the following settings in the LoopMaster service software must be done in the indicated order:

- Turn on the measurement system: see chapter 7.1.1
- Address of traffic data acquisition system at the RS485 data interface: see chapters 7.1.7 and 7.2.3
- Check consistency of loop type used acc. to ASTRA-SWISS definitions and detector parameter loop type, if necessary, correct loop head distance: see chapter 7.1.3 and 7.3.1
- Frequency adjustment: see chapter 7.1.2
- Detection of wrong way drivers, directional logic (only if necessary): see chapter 7.1.6
- Length correction (only if necessary): see chapter 7.1.5

Malfunctions, indicated at the **ERR** LED are displayed in LoopMaster and can be determined by the blinking of the channel LED with the help of Table 2. If operation is faultless, the correct function of the traffic data acquisition should be checked on location using single vehicle data after having detected a minimum of approx. 50 cars. Classification, vehicle length and driving direction can be controlled by monitoring cars passing the loop system and comparing them with the vehicle data read out at the service interface (see chapter 6.3). An exact evaluation of speeds can only be done by means of a calibrated speed reference (e.g. laser / radar gun).

3.5 Notes for installation

The device has a power consumption of approximately 1 W. Please note, in particular when installing a larger number of SW3224 or presence of other heat-generating devices, the following instructions.

When installed in an enclosure or cabinet, a sufficient heat dissipation must be ensured. The ambient temperature surrounding the device and thus the temperature inside this enclosure or cabinet must not exceed the maximum allowable operating temperature of 80°C.

4 Operating the SW3224 with LoopMaster

4.1 General

The SW3224 is operated via service interface on the front (**SERVICE**) by means of the **LoopMaster** service software installed on a PC or laptop computer. The detector is connected directly with an USB interface of the PC.



NOTE

- Please use an USB adapter cable with 3.5 mm jack plug. SWARCO TRAFFIC SYSTEMS GMBH label KA_Service_AJ-USB (order number: D.000.604.466).
- Please use LoopMaster only, the preceding software IGBT does not support this detector type.

In LoopMaster the following interface parameters can be set: (**Settings – Communication settings...**):

- COM port
- Baud rate: 4800 Baud (default)

LoopMaster provides an extensive help function, therefore only the most important functions will be described in the following.

LoopMaster is available in the download area on our website under www.swarco.com/products/software/other-software.

4.2 Functionalities

In the parameter and diagnosis windows of LoopMaster the parameter and diagnosis values used in the SW3224 are displayed as clear text. There are windows for individual channels, normally 4 in the SW3224, and one detector window. The detector window lists the according values for several channels and / or of the complete device. The data of these values between LoopMaster and SW3224 is transferred together with the channel values.

The displayed values in the channel and detector windows are classified into alterable parameter values and unalterable diagnosis values. The entry fields for the alterable parameters are white, the display fields for the diagnosis values are grey.

Besides these windows a terminal window is located at the left side of LoopMaster which logs the serial communication via service interface. In this window also all current vehicle data are listed.

When the LoopMaster is started, all channel and detector data are automatically requested and displayed in the according windows, the status bar at the bottom part of the window is updated.

SW3224 SN123456 E Dec 10 2012 V1.03 LC22

Figure 4: Example for the LoopMaster status bar

The displayed information are used to identify the detector hardware and firmware:

- Detector type, e.g. SW3224
- **Serial Number**, e.g. SN123456
- Country code of the service interface output, e.g. E (English) or D (German)
- Detector firmware date, e.g. Dec 10 2012 (10.12.2012)
- Version status of the detector firmware, e.g. V1.03 (Version 1.03)
- Identification for the detector-specific display in LoopMaster, loop configuration, e.g.: LC22: 2 loop systems with 2 double loops each

Opposite to detectors for traffic light systems, the SW3224 is normally used as double loop detector, i.e. in order to function a loop system with 2 inductive loops arranged successively is necessary. Channels 1 and 2 form the first loop system, channels 3 and 4 the second loop system.

This makes no difference in the operation of LoopMaster: the 4 channels are separately listed. However, please pay attention to the following notes.



NOTE

- In order to parameterize a double loop system, use the window of the according first channel. Alterable parameters are thus only available for channel 1 resp. channel 3.
- The detector automatically adopts the correct parameters for the according second channel of the loop system. The parameters of the channels 2 resp. 4 cannot be altered.
- The diagnosis values of the channels are still displayed individually.

5 Display and operating elements at the front panel

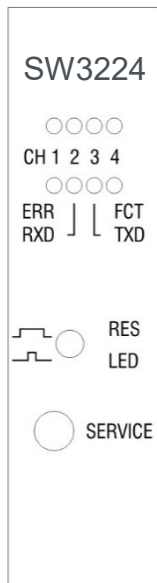

Figure 5: front panel of SW3224 with LEDs, pushbutton and service interface

The detector has an LED for each channel to indicate vehicle detection (**CH1...CH4**). Furthermore, in case of a malfunction, the LEDs display the cause of the malfunction (e.g. loop open) by means of a predetermined number of LED blinkings (see chapter 6.2).

The **ERR** LED is activated in case of a malfunction of at least one channel.

The reception and transmission processes of the RS485 data bus interface are indicated at the **RXD** and **TXD** LEDs for the reception and transmission direction of the SW3224 .

The **FCT** LED flashes with a frequency of 1 Hz during normal operation of the detector. With activation of MASTER-SLAVE synchronization, the flashing frequency during normal operation is reduced to 0.5 Hz.

The **RES** LED pushbutton has 3 functions, depending on how long the button is being pushed:

- **LED on / off:** Press button less than 1 sec,
all LEDs are deactivated or activated,
function can be disabled by means of the parameter
setting "LED-turnoff-time = 0"
- **Channel alignment:** Press button 1 – 2 s,
initialization of all active loop channels
- **Reset:** Press button longer than 5 s,
detector reset and subsequent alignment of all channels

All detector settings are made using the front service interface (labeled: "**SERVICE**").

6 Alignment and error diagnosis

6.1 Alignment

Alignment is defined as initialization of a detector channel. In doing so, all settings are configured according to the parameters saved in the EEPROM (e.g. frequency, sensitivity). There must be no extended vehicle passages during the alignment. If a convoy of vehicles passes during alignment, the SW3224 attempts to adjust to the gaps between the vehicles. There are no vehicle detections possible during the alignment. After the alignment, the channel is always in an "undetected" status.



ATTENTION!

When a channel is aligned, vehicles located within the range of action of the induction loop at this point in time are ignored. This means that they are not detected during and directly after the alignment!

In the following events, the SW3224 carries out an alignment:

- after switching on the supply voltage (**Power On Reset "POR"**)
- as a result of modification of relevant parameters (e.g. frequency, loop type, channel function) via service or data interface
- as a result of pushing the RESET button
- after reset request via interface
- as a result of an internal RESET (e.g. watchdog or power fail).

After RESET, all activated channels are aligned. When prompted by a parameter transfer via service interface by means of LoopMaster or RS485 bus, only the selected channels for which at least one parameter has changed are realigned. All other channels continue to operate without any influence on their detection in this case. The alignment takes approx. 1 sec. with an unaffected induction loop and may take longer e.g. with disturbances on the loop. The corresponding channel LED **CH1** ... **CH4** is activated during the alignment and additionally the **FCT** LED flashes faster (approx. 5 Hz). Once alignment has been successfully completed, the channel LEDs **CH1** ... **CH4** are switched off and used for the indication of the detection status.

6.2 Error detection and troubleshooting

Channel-related errors are indicated at the channel LEDs **CH1** ... **CH4** by blinking repeatedly every 5 s with a predetermined number of blinkings for each error.

Channel errors	Number of channel LED blinkings
Short-circuit loop	1
Open loop, loop broken	2
Frequency not adjustable	3
Disturbance	4
reserved	5
Maximum loop alignment duration exceeded	7
Loop type incorrect	8

Table 2: List of channel errors with allocation of the number of flashes to the channel LED

These errors are displayed in the channel windows in the LoopMaster as "channel error" diagnostic parameters (see chapter 7.3.4). Furthermore, the **ERR** collective error LED indicates an error status with at least one channel.

In case of a short-circuited or open loop, the alignment algorithm detects that the connected inductance (induction loop + feeder cable!) is outside the permissible range (see chapter 8.1). The error cause is to be found and eliminated.

If the selected frequency range cannot be set, the loop inductance lies outside the recommended range (see chapter 8.1). To solve this problem, set another frequency range (see chapter 7.1.2).

The error message "Disturbance" indicates external interferences during alignment. This causes longer alignment times (more than approx. 2 s per channel). The external interferences must be determined and eliminated in order to ensure the correct detector function. Otherwise, misdetections may occur, i.e. the according channel switches even without loop attenuation. The external interferences may be caused by electromagnetic fields or pulses in the environment of the induction loop or feeder cable. Selecting another frequency range may solve this problem.

If the disturbances are caused by other identical loop detectors, the interference can be eliminated by synchronizing the detectors by means of the synchronization leads of the terminal strip (see chapter 7.5.1).

The duration of the channel alignment is restricted to the set duration using the "maximum loop alignment duration" parameter. The error message "maximum loop alignment duration exceeded" is generated if this time is exceeded.

After troubleshooting, an alignment of all channels or a reset of the SW3224 with subsequent alignment of all channels can be initiated using the pushbutton on the front panel in order to restore correct functionality.

If the channel flag "Automatic recalibration in case of channel error" (see chapter 7.1.10) is activated (factory setting: deactivated), a cyclical alignment is performed in case of a channel error. At the latest 1 min. after troubleshooting, the channel faults will automatically be removed in this case, except for the following fault:

- Loop type incorrect

In this case also, a vehicle located within the range of action of the loop at the time of troubleshooting will be ignored.

If one loop of a double loop system is faulty, the other loop works in limited operation. A high-quality classification (e.g. ASTRA-SWISS10) is not possible anymore, because vehicle lengths and speeds cannot be determined. The classification will automatically be reduced to car-similar / HGV-similar vehicles. In order to reach the original data acquisition quality, the failure cause must be eliminated.

6.3 Automatic calibration and control of vehicle detection

The SW3224 is delivered with standard parameter values optimized for the permitted loop and feeder cable configurations. In order to further optimize the single vehicle detection, important characteristic values e.g. norm value and switch-on threshold resp. sensitivity for the connected loop / feeder cable configuration are permanently and automatically evaluated and stored non-volatile in the EEPROM. Thus, a power failure or reset does not influence the already reached detection quality.

The adjustment of the sensitivity is not possible, since the response thresholds for the vehicle detection are permanently evaluated by using the norm value. The automatic alignment usually has achieved sufficient accuracy after a detection of approx. 50 cars.

Afterwards, a control of the single vehicle detection can be done by visually comparing the vehicles with the data readouts at the service interface on the front. To do so, the LoopMaster terminal window or any terminal program can be used. The following data are displayed separated by detection system:

- Vehicle class
- Vehicle speed
- Vehicle length
- Driving direction
- Vehicle distance

Examples:

- **sy.2 l: 4,31 m v: 75,6 km/h di.0 dis.:910 m car**

Detection system 2 (channel 3 / 4): vehicle class car, length 4.31 m, speed 75.6 km/h, driving direction 0 \equiv loop 3 \rightarrow 4, distance 910 m

- **sy.1 l: 7,97 m v: 60,5 km/h di.1 dis.: 87 m lorry**

Detection system1 (channel 1 / 2): vehicle class lorry, length 7.97 m, speed 60.5 km/h, driving direction 1 \equiv loop 2 \rightarrow 1, distance 87 m

- **sy.1 l: 5,21 m v: 54,3 km/h di.0 dis.: 14 m delivery van**

Detection system1 (channel 1 / 2): vehicle class delivery van, length 5.21 m, speed 54.3 km/h, driving direction 0 \equiv loop 1 \rightarrow 2, distance 14 m

With the standard width of the terminal window (16 characters) the traffic data is displayed in 4 rows per vehicle. When the width is set >63, the data is displayed in one row per vehicle.

Afterwards, the norm value should be checked (LoopMaster: channel diagnosis value). The norm value is different for each loop type and is mainly determined by loop length and installation depth. Also, the norm value is reduced when the length of the loop feeder cable is increased. Typical values for the norm value with common loop types depending on the feeder cable lengths are indicated in the following table:

Loop type*	Detector type / Order number		Feeder cable length [m]**	Norm value permitted tolerance: +10 % / -20%
TLS type 1 (loop length 2.5 m)	MC3224T9I	D000611169	20***	2.7 %
	MC3224T6I	D000611168		
	MC3224T2I	D000611167		
	MC3224SPI	D000611170	300	1.8 %
	CD3224T9I	D000611219		
TLS type 2 (loop length 1.0 m)	MC3224T9	D000611164	20***	1.5 %
	MC3224T6	D000611163		
	MC3224T2	D000611162		
	MC3224SL	D000611166		
	MC3224SP	D000611165	300	1.0 %
	CD3224T9	D000611184		
	CD3224T9V2013	D000611221		
	CD3224SP	D000611201		
ASTRA-SWISS (loop length 2.0 m)	SW3224T10	D000611199	20***	2.5 %
	SW3224SL	D000611206	300	1.6 %

*: Installation depth approx. ca. 5 – 7 cm

** : Cable type and connection according to chapter 3.3

*** directly connected loop cable without additional feeder cables

Table 3: Typical norm values

If you notice strongly diverging values or big differences between the loops of a double loop system, the quality of the data may be reduced. Reasons for this can be e.g. metallic objects in the area of the inductive loops.



ATTENTION!

For the precise and reliable vehicle detection, a homogenous (uninterrupted) magnetic field in the loop area is indispensable. Metallic components such as manhole covers and reinforcement in concrete carriageways as well as the installation of inductive loops in bridges with metallic fundaments can have a negative influence on the quality of the vehicle detection.

Without these influences and with correctly installed inductive loops, the difference of the norm value between the loops of a double loops system is usually less than 3 %.

For the exemplary reference value for TLS type 2 without additional feeder cable from

Fehler! Verweisquelle konnte nicht gefunden werden. this is 1.45 % and 1.55 % as norm values of the two loops.

Further reasons for bigger differences are different installation depths, number of windings or loop dimensions.

7 Parameters and functionality

The parameters are divided into

- Channel and/or loop system related parameters (frequency etc.), can be configured separately for each channel. In the following “channel” will also be used for a (loop) system consisting of 2 channels.
- Device parameters (e.g. synchronization), are settings which apply to the entire device (refer to section 7.2)

In addition to the user-adjustable parameters, the SW3224 also provides diagnostic data, which can be displayed in the LoopMaster. These values cannot be directly modified but result from the parameters (e.g. frequency from configured frequency range), are determined during operation (e.g. last amplitude) or result from the unit operating status (e.g. channel status, RESET counter). It is to be noted that all displayed data show the current status of the detector at the time of parameter request (LoopMaster menu item: "Read parameter").



ATTENTION!

The user must take care that the configured parameters ensure a logical and reliable detector function.

7.1 Significance of the channel parameters

The channel parameters comprise all channel-specific settings. After the data transfer to the detector, the detector checks all parameters for modification in comparison to the current settings. An alignment is only performed if at least one of the channel parameters has changed and the modified values are stored non-volatile in the EEPROM. Changes in the parameters which have no influence on the acquisition of measurement values do not cause a new alignment (e.g. length corrections). In a double loop system usually both channels are initialized.

7.1.1 Channel function

The channel function enables or disables channels. This can e.g. be used to switch off channel no longer required or to disable the traffic data acquisition at faulty inductive loops.

7.1.2 Frequency range

The loop frequency of each channel can be set to one of four frequency ranges.

Frequency level	Frequency range [kHz]
'0'	30 - 44
'1'	45 - 64
'2'	65 - 84
'3'	85 - 110

Table 4: frequency levels and ranges, factory setting (bold)

This can contribute to interference suppression during operation of several detectors interconnected by means of loops and / or a loop feeder cable (see **Instructions for setting the frequency with several detectors**).

With a known frequency of external interference sources, interference suppression can likewise be achieved by selecting an appropriate frequency range. The channel is faulty, if the selected frequency range cannot be set (see also chapter 6.2).

The oscillator of the SW3224 is designed in such way that, when using loops with inductances within the recommended range, all frequency ranges can be used (see chapter 8.1).

In order to have the best noise immunity, the maximum measurement frequency should be used.

Instructions for setting the frequency with several detectors

Because of the loop control in multiplex mode, the channels of the detector cannot interfere with each other. Thus, the user must only pay attention that the interconnected channels of several detectors have a sufficiently large frequency gap.

An interconnection of detector channels can be the result when the distance between inductive loops is too small and / or when they share the loop feeding. The smaller the distance between the loops and the longer the channels are e.g. led through a shared feeder cable, the larger is the interconnection.



ATTENTION!

Please observe that the interconnected detectors must work with different frequencies and that additionally the synchronization function must be activated (see chapter 7.5.1).

The difference of measurement frequencies should be approx. 5 - 10 kHz and is normally achieved when different frequency ranges are chosen for several detectors. The channel diagnosis value frequency shows the current measurement frequency (see chapter 7.3.7). This can be used to control the above-mentioned minimum frequency gap when the same frequency ranges are set for several detectors.

When several SW3224 are used as a standard for a detection cross section, e.g. on the motorway, we recommend the following procedure to set the frequency.

Normally, 2 resp. 3 lanes per driving direction must be detected. To do so, 4 resp. 6 double loop measurement systems are necessary, which are distributed over the different detectors, i.e. systems with longer feeder cables use lower frequencies and systems with shorter feeder cables use higher frequencies.

Here, it is sensible to set the frequency ranges for both measurement systems of a detector identically.

Detector	1		2	
Driving direction	1		2	
Lane	1	2	1	2
Frequency range	3	3	2	2
Frequency [kHz] (2 channels per system)	92 and 91	86 and 87	66 and 67	77 and 76

Table 5: Example for a motorway with 2 lanes per driving direction

Example for 2 lanes

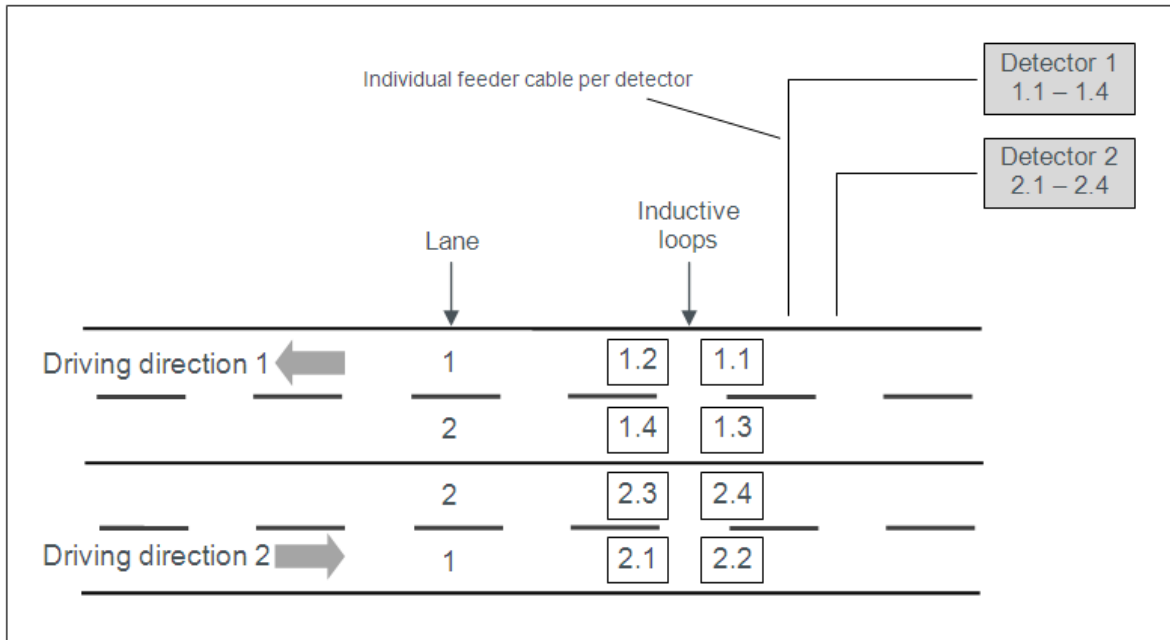

Figure 6: Example for 2 lanes

As shown, with 2 lanes it is reasonable to allocate the lanes of one driving direction to one detector. The inductive loops of neighboring lanes of one driving direction don't interfere with each other because of the multiplex mode, the large distances of the inductive loops of different driving directions also avoid interference. If the feeder cables are separate for each driving direction, an interference of the two detectors can be ruled out. If these conditions are not met, different frequency ranges must be used as indicated in the example.

Detector	1		2		3	
Driving direction	1		1 / 2		2	
Lane	1	2*	3*	1**	2**	3
Frequency range	3	3*	2*	2**	1**	1
Frequency [kHz]	86 - 87	92 - 91*	76 - 77*	71 - 72**	55 - 55**	51 - 51

Table 6: Example for a motorway with 3 lanes per driving direction
 * / **: possible interference driving direction 1 / 2

Example for 3 lanes

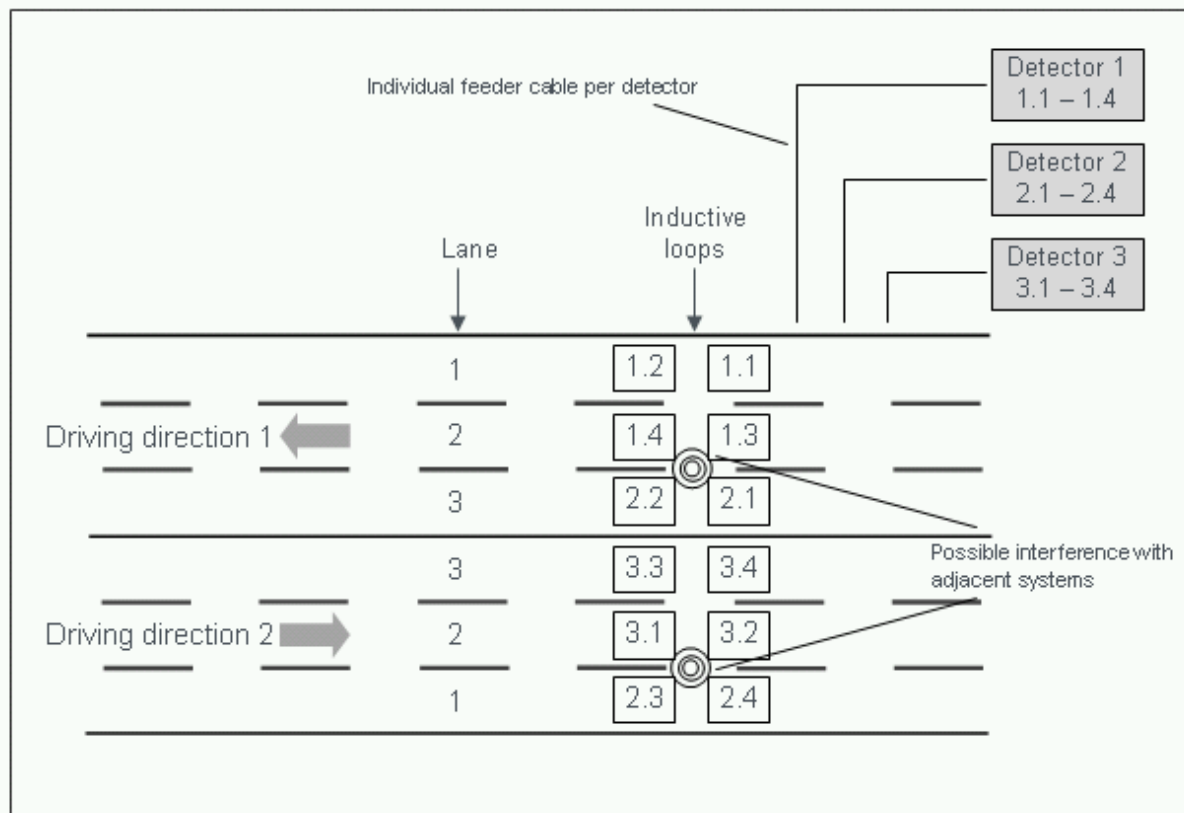

Figure 7: Example for 3 lanes

Also, in this case the inductive loops of different driving directions cannot interfere with each other either if the feeder cables are separated. Thus, only the inductive loops of neighboring lanes in one driving direction which are controlled by different detectors are subject to a direct interference (values in Table 6 marked in bold). Here, with identical measurement frequencies, an interference of measurement systems would exist because of the sidewise distance of approx. 1.6 m up to 2.0 m. The selected frequency ranges and the resulting measurement frequencies avoid this as far as possible (frequency gap > 5 kHz). Further improvement can be reached by activating the synchronization function (see chapter 7.5.1).

Limitation of the frequency adjustment

For a loop inductance of approx. 150 µH as usual for ASTRA-SWISS loops and the usage of the feeder cables indicated in the technical data description (see chapter 8.1), the frequency adjustment can be limited if the feeder cable is longer than approx. 150 m. This means that the highest frequency level is no longer adjustable. The alignment fault resulting from this is displayed as "frequency not adjustable" in the LoopMaster and shown at the **ERR** LED and by the channel LED blinking three times. The problem can be solved by reducing the frequency level.

7.1.3 Loop type and loop distance

The parameter loop type is of great importance for the classification. The SW3224 uses separate classification algorithms for each loop type resp. loop length because identical vehicles generate different vehicle patterns with different loop lengths. Thus, for each loop length a separate vehicle pattern database is used in order to reach a very high classification accuracy.

Since the loop length is directly related to the loop type and since it cannot be changed, it is displayed as diagnosis value (see chapter 7.3.1).

For the standard loop type with defined loop distance, the loop distance cannot be changed. Thus, a second loop type with variable loop distance is defined. Here, the parameter loop distance defines the head distance of the loops e.g. from the beginning of the first loop to the beginning of the second one. Values which are too low or too high are automatically limited to the permitted range.



ATTENTION!

In order to reach a highly-precise classification, the loop geometry (length and width) may not differ from ASTRA-SWISS definitions.

7.1.4 Smoothing of measured values

The smoothing of measured values is used to suppress noise. This can be caused by other detectors, but also from external noise sources such as AC power supplies, communication lines, etc. in the field of induction loops or their leads.

The duration of the measured value smoothing is parameterized in 10ms increments. The number of measurement values used for the arithmetic averaging is calculated automatically for each channel:

$$\text{Number of smoothed values} = \text{duration smoothing of values} / \text{cycle time}$$

The current cycle time is displayed as a detector diagnostic value in LoopMaster (see Section 7.4.1).

When setting the measurement smoothing, please note that the data acquisition for motorcycles can be influenced at a speed > 100 km / h (very short damping duration). Too strong measured value smoothing may result in these vehicles not being detected. The setting of the measurement smoothing is limited to approx. 100 ms. In the factory setting the measurement smoothing is deactivated (0 ms).

The measured value smoothing is available at firmware versions greater than 1.05.

7.1.5 Vehicle length correction

An important criterion for the vehicle classification is the detected vehicle length. When a vehicle passes the loop, a vehicle length is determined which is not the actual vehicle length. This so-called “attenuation-length” is partly influenced by the loop length. In order to obtain the real length, a length correction is used. The resulting length is then calculated as follows:

real length = length of attenuation - length correction
permitted value range length correction: 0 – 20 dm

Changing the length correction value can be necessary in the following cases:

- Strongly diverging loop lengths. In this case, please take into account the strong influence of the actual loop length on the classification accuracy
- Inductive loop laid in greater depth
- Metallic objects (manholes, reinforcement in concrete roads) in a distance of much less than 1 m

Otherwise, when using standard ASTRA-SWISS loops and observing the tolerances and / or geometry and laying depth, no length correction is needed; the correct length correction value is set as default for each loop type resp. loop length.

The adjustment of the length correction may be effected only after a new alignment and the detection of approx. 50 cars. For this, the length value of a car with known length as indicated at the service interface (e.g. VW Golf 4.0 – 4.2 m) must be checked and the length correction must be adjusted until there is an accordance to the known vehicle length. A higher / lower value of the length correction causes a lower / higher value of the real length.

7.1.6 Detection of wrong way drivers

This parameter is used in double loop systems as addition to the integrated detection of the driving direction in order to set the recognition of wrong way drivers. To do so, the “normal” driving direction is determined and when a vehicle passes the loops in the opposite direction, a flag for wrong way drivers is set in the single vehicle telegram. In traffic data acquisition systems this can be used for e.g. alarm messages.

In the single vehicle data of the service interface (see also chapter 6.3) the “normal” driving direction is displayed as “di.“, the wrong way driver as “ww.“.

If the evaluation of direction is turned off, the wrong way driver message on the data and service interface is deactivated.

Detection of wrong way driver	off		“Normal“ driving direction			
			1 st → 2 nd Double loop		2 nd → 1 st Double loop	
Driving direction channel	1 → 2 resp. 3 → 4	2 → 1 resp. 4 → 3	1 → 2 resp. 3 → 4	2 → 1 resp. 4 → 3	1 → 2 resp. 3 → 4	2 → 1 resp. 4 → 3
Service interface: Single vehicle readout	di.0	di.1	di.0	ww.1	ww.0	di.1
Data interface: Wrong way driver flag single vehicle telegram	0	0	0	1	1	0

Table 7: Overview wrong way driver detection: Parameterizing and data readout

In order to avoid incorrect messages of wrong way drivers, the **minimum speed wrong driver detection** can be used (factory setting 20 km/h). The wrong way driver message will then be ignored when a vehicle drives backwards below this threshold, e.g. service vehicles on highways.

For more options to parameterize the wrong way driver detection, see chapter 7.1.11.

7.1.7 Address data bus

The address is part of the manufacturer-specific protocol. For each detection system a unique data bus address must be defined by means of this parameter. The setting can be done by means of LoopMaster or the hardware address (see chapter 7.2.3).

7.1.8 Sensitivity / measuring time

In contrast to detectors for traffic signal installations, the adjustment of these parameters is limited, because they have great influence on the accuracy of the vehicle detection (e.g. classification and speed measurement).

Therefore, the sensitivity cannot be changed. The SW3224 has an automatic sensitivity adjustment and very short measurement times in order to ensure optimum single vehicle detection also at high speeds.

When the detector is delivered, the measurement time is optimally set for the application and usually does not need to be changed.

7.1.9 Hold time

The hold time is initiated during each detection. If the hold time elapses without the channel becoming free, the channel will be reset. If a vehicle is still on the loop at this point in time, this vehicle will be ignored.

If the vehicle leaves the loop afterwards, the original sensitivity is reached at approx. 4 s after leaving the loop. Further vehicles restart this time period.

With static hold time (infinite hold time), external interferences may reduce the actually achievable hold time. Setting a finite hold time generally ensures reliable operation in these cases. Still, the requirements of traffic data acquisition, which don't permit a short hold time, must be observed (e.g. detection of congestions).



NOTE

If congestion detection is necessary due to traffic data acquisition requirements, the default "infinite hold time" must not be changed.

The channel alignments initiated by exceeded hold times are displayed in the channel diagnostic value in the (see chapter 7.3.5).

7.1.10 Channel flags

The channel flags are used to configure the following binary channel parameters:

- Automatic recalibration in case of channel error (for functionality see chapter 6.2)
- Contact position of the switching outputs
- Contact position in case of an error

The **contact position of the switching outputs** (open collector) can be influenced in the following manner:

- **Normally Open (NO):** open collector HIGH when loop not occupied (factory setting),
- **Normally Closed (NC):** open collector LOW when loop not occupied

On detection (loop occupied), the output switches to the respective other position.

The **contact position in case of an error** in the channel can be adjusted as follows:

- Switching output as loop unoccupied
- Switching output as loop occupied (factory setting)

7.1.11 Extended channel flags

It is not possible to change the “double loop function (v, l, di.)” in the extended channel flags, as they are configured by default. The activated double loop function is therefore shown by “On (unchangeable)”.

The following channel flags are used to activate / deactivate the functions of the wrong way driver detection:

- Motorcycle detection
- Advanced plausibility wrong driver detection
- Wrong driver detection motorcycles

In applications where the **Motorcycle detection** (default setting On) is not necessary resp. where there are too many incorrect detections due to disturbances in the periphery of the loops, the detection of motorcycles can be deactivated. Disturbances can be caused e.g. by high-powered ventilators in tunnels and inductively actuated LED illumination.

Activating the **Advanced plausibility wrong driver detection** (default setting On) also activates an additional check of the vehicles which prevents false wrong way driver messages, especially on multi-lane highways and motorways. The wrong way driver flag in the single vehicle telegram is only set if all plausibility checks were successful. In applications where only direction recognition without further plausibility checks is desired (e.g. on country roads or inner cities), this flag can be switched off.

The **Wrong driver detection motorcycles** (default setting Off) is used for the separate activation / deactivation of the wrong way driver messages caused by motorcycles. Motorcycles represent a special case, because the occupancy of both double loops as an important criterion for driving direction detection is usually not given. This can limit the accuracy of wrong way driver detection for motorcycles.

7.1.12 Maximum loop alignment duration

Under unfavorable application conditions, the alignment duration of a channel may be considerably longer as a result of external interferences. This parameter limits the alignment duration per channel to the indicated value and sets the channel to fault, in order to prevent unreliable detection behavior. This function is deactivated with the value 0. On activating the function "Automatic alignment case of error", a new alignment attempt is cyclically (1 min) initiated.

7.1.13 Noise threshold

The noise threshold defines, to what extent the disturbing signal might have an influence on the detection and the temperature compensation. The loop measurement signal is superposed with disturbing signals resp. a noise. Reasons for this can be interferences from other induction loops or external disturbing signals. The smaller this value, the higher is the sensitivity to disturbances; the higher this value, the better interferences are suppressed. However, higher noise threshold values can have a negative influence on the internal measurement value resolution. As a function of the automatically evaluated switch on threshold, the values of the noise threshold are limited to the permitted minimum and maximum values.

The default values should only be changed in exceptional cases if the detector function is strongly influenced by interferences. In this case, the noise threshold must be raised step by step.

7.2 Significance of the device parameters

The device parameters are settings that affect several or all channels of the detector and are transmitted together with the channel data between the LoopMaster and the detector.

7.2.1 Language service interface

With this parameter, the text readouts on the service interface (e.g. vehicle data) can be switched to the desired language. Please note that this does not change the language setting in LoopMaster.

7.2.2 Service interface output functions and baudrate

The following output functions can be set:

- Single vehicles (standard): Format see chapter 6.3
- Single vehicles (LVE compatible), Single vehicles (HEX. test mode STS): STS-specific readout formats
- Vehicle class sums
- Modem (AT command): only in conjunction with Gecko Cloud traffic data detection system

When setting the vehicle class sums, separate counters are readout according to the current classification options for each vehicle class. In addition to the output of the vehicle class of the current vehicle, the counter value of the class and the vehicle total counter are increased by 1.

Example vehicle class sum readout (TLS-8+1-classification):

```
Sy.1 Fzg.summen Pkw      TLS 8+1 K 00021 P 00011 L 0000 Lf 0002 PA 0001 Sa 0005 LA 0000 Bu 0001 Kr 0000 nk 0000
Sy.1 Fzg.summen Pkw      TLS 8+1 K 00022 P 00012 L 0000 Lf 0002 PA 0001 Sa 0005 LA 0000 Bu 0001 Kr 0000 nk 0000
Sy.1 Fzg.summen LkwA     TLS 8+1 K 00023 P 00012 L 0000 Lf 0002 PA 0001 Sa 0005 LA 0001 Bu 0001 Kr 0000 nk 0000
Sy.1 Fzg.summen Lkw      TLS 8+1 K 00024 P 00012 L 0001 Lf 0002 PA 0001 Sa 0005 LA 0001 Bu 0001 Kr 0000 nk 0000
```

Abbreviations:

K: Kfz (sum of all vehicles), **P:** car, **L:** truck, **Lf:** van, **PA:** car with trailer,
Sa: lorry articulated, **Bu:** bus, **Kr:** motorcycle, **nk:** not classified vehicles

The counters are reset when the vehicle class sum readout is activated, or via LoopMaster (menu Parameter – Reset counter)

The baud rate of the service interface can be set between 2400 and 115200 baud. The default value is 4800 baud.

7.2.3 Hardware address data bus

The hardware addressing can be activated by setting an address > 0. The addressing of the detection systems is automatically formed from the hardware address. Starting with the 1st system, the addresses are assigned in ascending order for all systems. The resulting addressing is displayed in the corresponding channel parameter (see chapter 7.1.7).

The hardware addressing can be deactivated by means of a device flag (section 7.2.5), the addressing is then done with LoopMaster and the channel parameter..

For hardware addressing, a 4-pole DIP switch is located behind the removable front panel. With switch 2 – 4 hardware addresses can be set from 0 to 7, see Figure 8.

DIP switch				Hardware address
1	2 (LSB)	3	4 (MSB)	
Termination	OFF	OFF	OFF	0 (factory setting)
	ON	OFF	OFF	1
	OFF	ON	OFF	2
	ON	ON	OFF	3
	OFF	OFF	ON	4
	ON	OFF	ON	5
	OFF	ON	ON	6
	ON	ON	ON	7

Table 8: setting of hardware address

The factory setting switches 2 – 4 OFF (address 0) deactivates the hardware address.

To remove the front panel: Push apart slightly, the housing at the long side of the front panel and loosen the panel at the 4 fixation points.

Please observe the information on termination and the notes in chapter 7.5.2.

7.2.4 Baud rate data bus

With this parameter, the baud rate of the data interface can be set. Usually, the default setting of 9600 baud is sufficient. The set baud rate must be consistent with the baud rate used by the data bus master.

7.2.5 Detector flags

The following settings can be configured:

- Detector synchronization: MASTER / SLAVE
- Hardware address for data bus: ENABLED / DISABLED

If several detectors are to be synchronized with one another in order to avoid their mutual interaction, the MASTER setting must be configured here for **just one** detector. For further information concerning **synchronization** see chapter 7.5.1.

The hardware address can be disabled by the setting "**Hardware address for data bus: DISABLED**". The already saved EEPROM address is used in this case, or a new address can be defined by means of the parameter "Address data bus". With modification of this flag, a detector reset is performed.

7.2.6 LED turn-off time

After the LED turn-off time has elapsed, the LEDs are switched off. Briefly pressing the pushbutton or communicating via the service interface reactivates the LEDs. The value 0 (factory setting) deactivates the turn-off function.

7.3 Significance of the channel diagnostic values

These values are generated for each channel by the detector during operation. The values indicated apply for the time of parameter request; if necessary, they are to be updated by means of parameter request from the detector.

7.3.1 Loop length

The loop length is directly related to the loop type and is displayed as unchangeable diagnosis value.

7.3.2 Channel status

The channel status contains the following binary data:

- Channel occupied: current detection status (detection yes / no)
- Channel error: current error status (error yes / no)
- Channel error history (since POR): channel was previously faulty (yes / no).

The "Channel error history (since POR):" flag is reset in case of a **Power On Reset** (abbreviation: POR, i.e. reset on switching on the supply voltage).

7.3.3 Vehicle classification

The vehicle classification displays the classification options set as default. The following options are available acc. to ASTRA:

- Standard: SWISS10
- Option 1: SSVZ
- Option 2: car-similar / HGV-similar vehicles

7.3.4 Channel error

In case of a channel error, the channel error displays the error causes evaluated by the detector during alignment (see chapter 6.2).

7.3.5 Alignment counter and hold time exceedance

This value indicates the alignment processes performed since the last POR. This can be alignment processes initiated by parameter modification, RESET conditions or alignments caused by error conditions during loop operation. This information may therefore contribute to error detection, since unreliably operating loop channels and devices can be detected here.

The number of exceeded hold times is indicated in a separate counter and is also included in the number of (total) alignments. In the default setting of the hold time (infinite) there are no exceeded hold times possible.

These values can be reset using the LoopMaster menu item: "Reset counter".

7.3.6 Inductance

The inductance of the inductive loop (including feeder cable!) is indicated in μH with a resolution of $10 \mu\text{H}$. The inductance is determined with an accuracy of approx. $\pm 20 \%$ within the recommended inductance range.

7.3.7 Frequency

The frequency indicated here in kHz lies within the set frequency range and is used e.g. for controlling the frequency gaps to channels of other detectors (see **Instructions for setting the frequency with several detectors** in chapter 7.1.2).

7.3.8 Turn-on threshold, maximum and last amplitude

All these values are displayed in the unit [%] and can therefore be directly related to one another and to the nominal value:

- The turn-on threshold is automatically evaluated from the norm value.
- Example relation turn-on threshold – last amplitude:
last amplitude 1.200 %,
turn-on threshold 0.100 %:
i.e. the last vehicle had a maximum detuning value which was 12 times higher than the turn-on threshold.

If the value exceeds resp. falls below the **turn-on threshold** the "channel occupied" resp. "channel not occupied" message is issued on the channel LED and the switching output.

The **maximum attenuation** indicates the maximum detuning since the last alignment and should be approx. 2 – 3 times of the norm value.

These values can be reset using the LoopMaster menu item: "Reset counter"

7.3.9 Norm value

This diagnosis value indicated the average value of the attenuation amplitudes of cars in the unit [%] and is used to control the automatic calibration (see also chapter 6.3).

7.3.10 Alignment cause

The alignment cause indicates the reasons for the numbers indicated in the alignment counter and hold time exceedance:

- **Exceedance of measurement value:**
Cause e.g. for a following channel fault loop open or short-circuited
- **Norm value beyond the permitted range:**
If the detected norm value is too low during the automatic calibration (see chapter 6.3), the calibration is restarted with the basic settings. If this error repeatedly occurs, the error cause (e.g. loop feeder cable too long, road or bridge reinforced by iron, loops are passed diagonally due to road works) must be evaluated and, if possible, eliminated.
- **Error other system channel, system alignment:**
In a double loop system (channel 1, 2 resp. 3, 4), the alignment was initiated by the according other channel.
- **Exceedance of hold time:**
Due to the exceeded hold time, an alignment was performed for the channel and the counter for hold time exceedance was increased.
- **Operation (interface, switch):**
The alignment was initiated by the user by pressing the reset pushbutton or by parameter modification by means of LoopMaster.

- **Synchronization:**
An alignment was initiated by a modification in synchronization (see chapter 7.5.1).
- **Monitoring of double loop system:**
In a double loop system, the two channels monitor each other. If one channel notices a malfunction of the other channel (e.g. caused by “get stuck”), an alignment of the loop system will be performed.

These values can be reset using the LoopMaster menu item: "Reset counter"

7.4 Significance of the device diagnostic values

These values are generated by the detector during operation. The values displayed are valid for the time of parameter request. If necessary, they are to be updated with a parameter request from the detector.

7.4.1 Reset counter, reset cause

The value reset cause indicates in bit-coded form the reason for the reset, the reset counter indicates the number of resets since the last POR. These values can be reset using the LoopMaster menu item: "Reset counter"

7.4.2 Cycle time

The cycle time in ms is the sum of the total measuring times of all channels (chapter 7.1.8):

$$\begin{aligned} \text{Cycle time} = & \text{measuring time, channel 1} \\ & + \text{measuring time, channel 2} \\ & + \text{measuring time, channel 3} \\ & + \text{measuring time, channel 4.} \end{aligned}$$

When the synchronization function is activated, the cycle time is the sum of the accordingly longest channel measurement times of all synchronized detectors. Please note that the cycle time should not exceed 8 ms.

7.5 Description of the special functions

7.5.1 Synchronization

If setting different frequency ranges (see chapter 7.1.2) alone does not lead to decoupling, the synchronization function can be used to minimize or eliminate e.g. false detections with detectors which are interconnected via loop feeder cable or in a direct way. The synchronization function ensures that the same channel is measured at all connected devices at any point of time.

When connecting the inductive loops, the following must be observed: The inductive loops with small distance to each other must not be connected to channels with the same channel number. Different channel measurement times are automatically taken into account by using the longest measurement time of the according channel group to determine the total measurement time of the channel. If systems are interconnected in an especially strong way, additionally different frequency ranges must be used.

To activate the synchronization first the bus system TBUS, which can be integrated in the DIN-rail, must be installed (see chapter 8.4.3). The synchronization line of the detectors, as well as the power supply and the RS485 data interface are then connected with each other via this bus system. At the middle connection of the screw clamp of the TBUS (clamp 3) the synchronization line can be wired with further devices (maximum 30) such as detectors with identical synchronization methods installed in a rack (e.g. MC2224).

Additionally, exactly one detector must be defined as MASTER. All other devices must remain in the default setting SLAVE.



ATTENTION!

Configuration of several MASTERS is not permitted!

For SLAVE detectors, that are already synchronized with a MASTER, the activation of the MASTER function will automatically be prevented.

The MASTER-SLAVE function is a device parameter and is to be found in the corresponding LoopMaster parameter window. The setting is transmitted to the detector by the command "Write to device..." and by selecting a channel.

When the MASTER-SLAVE setting is changed no RESET is executed and the traffic data acquisition is not interrupted. The start and the end of the SLAVE-synchronization is performed as part of an alignment of all channels of the SLAVE units if:

- a MASTER is activated when synchronization is not yet activated (start of synchronization)
- the MASTER executes a reset (start of synchronization)
- the MASTER is deactivated while synchronization is activated (end of synchronization)

After all detectors have finished the initialization of synchronization and the channel alignment, all **FCT** LEDs flash synchronously with a frequency of 0.5 Hz, however, the ones of the MASTER inversely to the SLAVE units.

7.5.2 Notes concerning the data bus function

Data readout is performed via RS485 data bus interface in a master/slave polling mode. The protocol to be used by the controller (master) for requesting the detectors (slaves) and the data contents are defined in a separate description, further specifications of the data bus interface are listed in the technical data (see chapter 8.1). The protocol description "Manufacturer-specific telegram definition" is available on request.

To terminate and for addressing of the RS485 bus at the detector, a 4-pole DIP switch is located behind the front panel which can be removed:

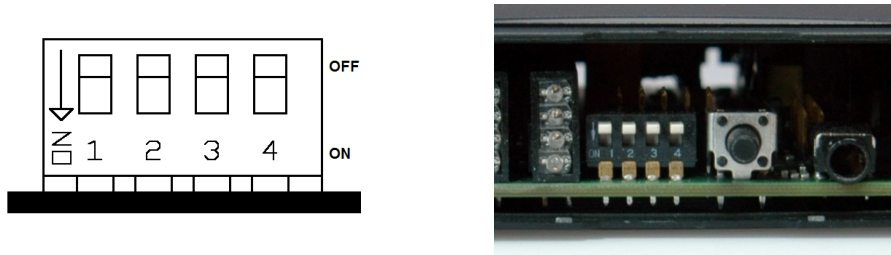

Figure 8: Switch for termination and addressing of RS485 interface

No.	Function switch OFF	Function switch ON
1	termination resistance 120 Ω deactivated (factory setting)	termination resistance 120 Ω activated
2-4	Hardware address see chapter 7.2.3	

Table 9: Function of switch for termination of RS485 interface



NOTE

As default the switches 1 - 4 are in OFF position, i.e. the RS485 bus is not terminated and hardware address is 0! Activate the termination once at the detector at the end of the RS485 bus line!

With lower baud rates (e.g. in default setting 9600 baud) and with short data bus lengths < 1 m, usually no termination is necessary.



ATTENTION!

The DIL-switches may only be set when the device is not connected to power supply. To do so, unplug all connections of the device and take it out of the DIN-rail.

To remove the front panel: Slightly push apart the housing at the long side of the front panel and loosen the panel at the 4 fixation points.

8 Appendix

8.1 Technical data

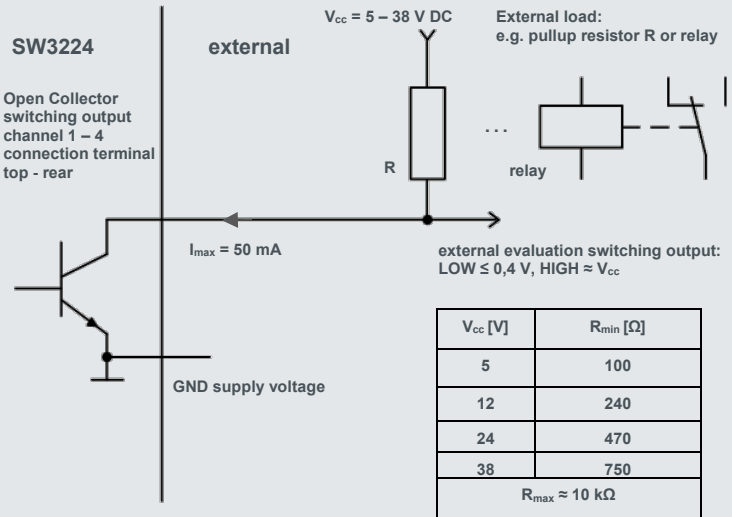
Technical Data													
Supply voltage	Standard: nominal voltage 24 V DC, range: 10 V DC - 38 V DC optional: 5 V DC +/- 5 % (regulated and load-independent), on request												
Power consumption	max. 0.7 W at 24 V DC												
Loop frequency range	30 kHz – 110 kHz												
RS485 interface	9600 baud, 11-bit transmission frames, 8 data bits, even parity, 1 start bit, 1 stop bit transmission procedures in accordance with IEC-870, asynchronous, half-duplex, manufacturer-specific telegram content available on request Termination resistance 120 Ω and pullup / pulldown resistance adjustable via switch. Connection see chapter 8.4.2 and 8.4.3												
Service interface (at front, "SERVICE")	USB adapter cable with 3.5 mm stereo phone connector (TRS), label: KA_Service_AJ-USB order number: D.000.604.466												
Switching outputs	switching output per channel: Open Collector (not potential free) $U_{max} = 38 \text{ V DC}$, $I_{max} = 50 \text{ mA DC}$, $P_{tot} = 125 \text{ mW}$ $I_c \leq 50 \text{ mA}$: $U_{CEsat} \leq 0,4 \text{ V}$  <table border="1" data-bbox="1066 1482 1332 1691"> <thead> <tr> <th>$V_{cc} [V]$</th> <th>$R_{min} [\Omega]$</th> </tr> </thead> <tbody> <tr> <td>5</td> <td>100</td> </tr> <tr> <td>12</td> <td>240</td> </tr> <tr> <td>24</td> <td>470</td> </tr> <tr> <td>38</td> <td>750</td> </tr> <tr> <td colspan="2" style="text-align: center;">$R_{max} \approx 10 \text{ k}\Omega$</td> </tr> </tbody> </table>	$V_{cc} [V]$	$R_{min} [\Omega]$	5	100	12	240	24	470	38	750	$R_{max} \approx 10 \text{ k}\Omega$	
$V_{cc} [V]$	$R_{min} [\Omega]$												
5	100												
12	240												
24	470												
38	750												
$R_{max} \approx 10 \text{ k}\Omega$													

Part 2	
Max. length of feeder cable	approx. 300 m for ASTRA-SWISS loop type (approx. 25 Ω), values apply to indicated loop induction ranges and the following cable types: A-2Y (L) 2Y Zx2x0,8 BdStIII or A-2YF (L) 2Y Zx2x0,8 BdStIII (Ø 0,8 mm, Z e.g. 2, 10) optional: feeder cable lengths up to approx. 600 m (on request)
Duration of loop measurement	1.5 ms per channel / 6.0 ms for 4 channels
Definition of inductive loops to be used	ASTRA-SWISS L x B: 2.0m x 2.0m (distance to median strip 0,8 / 1,0m) head distance: 5.0 m Number of windings: 4 Inductance range: 140 - 165 µH (with above mentioned data of inductive loops)
Total inductance (incl. feeder cable)	Maximum approx. 500 µH (for 300 m feeder cable with above mentioned inductive loops and cable types)
Ohmic resistance (loop and feeder cable)	Maximum 25 Ω
Isolation resistance of loops (without feeder cable)	At installation: > 1GΩ During operation: Values as low as approx. 1 MΩ are permitted, value must be constant
Device protection	Power supply, RS485: suppression-diode loop inputs: gas filled surge arrester, glow lamp, galvanic isolation with transformer
Dimensions	height: 99 mm, length: 114.5 mm, width: 22.5 mm
Operating / storage temperature	-25°C to +80°C / -40°C to +80°C
Relative humidity	maximum 95 %, noncondensing
Protection class	III (low voltage < 60 V DC)
Housing	Plastic housing polyamide (PA), IP protection class: 40, flammability classification acc. UL 94: V-0
Mounting	DIN-rail mounting (TS35 EN50022), to be installed in housing or cabinet with IP54 necessary (pollution degree 2)
Connection terminal	see chapter 8.4
Weight	approx. 130 g

8.2 Dimensions and housing layout

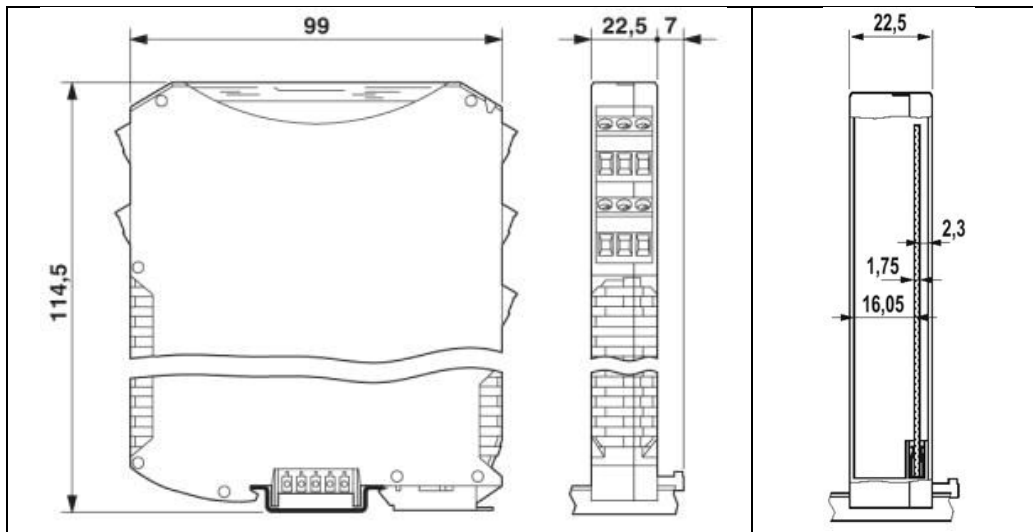

Figure 9: Dimensions (all measurements in mm)

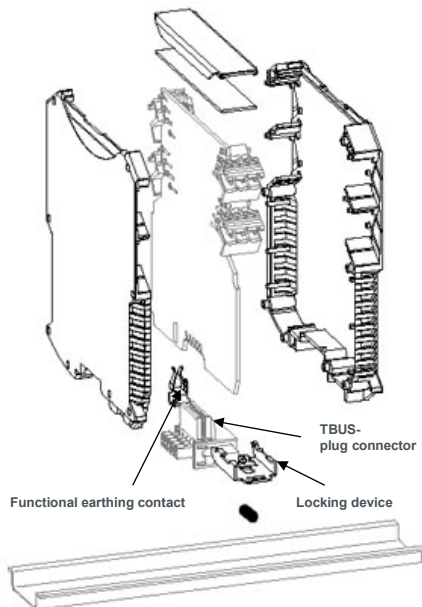

Figure 10: Housing layout

8.3 Mounting and dismounting

The device can be mounted on the DIN-rail by inserting it into the upper brim of the rail and then pressing it down until the locking mechanism at the back snaps into place.

When using a TBUS bus system, the according slots for the TBUS bus connector at the back of the device must be observed.

Afterwards, the correct position must be checked.

To dismount the device, e.g. a suited screwdriver can be placed in the slot at the bottom side of the locking mechanism at the back and then pressed down until the device can be slightly tilted up and taken out.

8.4 Pin assignment

8.4.1 Overvoltage protection of inductive loops

The overvoltage protection of the inductive loops (functional earth) is done via the contact integrated at the back and the DIN-rail. The DIN-rail must be permanently and with low impedance connected with the earth potential (PE).

8.4.2 Connection terminals on top and bottom side

In order to wire individual devices with supply voltage and RS485 data bus, use the top connection terminal in front (several devices: see following chapter).

Inductive loops resp. Open Collector switching outputs of the four channels are always connected with the plugs at the bottom resp. at the top on the backside.

Type: Plug with screw connection, 4-pole, black
 PHOENIX CONTACT MSTBT 2,5 / 4-ST BK (order no.: 1862551)
 Conductor cross section (flexible with conductor sleeve):
 0.25 – 2.5 mm² (AWG 24 - 14)

Position terminal clamp	Function
top – front	Supply voltage 24 V DC and RS485 data bus
top – back	Open Collector switching outputs channels 1 - 4
bottom – front	Inductive loops channel 1 and 2
bottom – back	Inductive loops channel 3 and 4

Table 10: Overview pin assignment at the top and the bottom

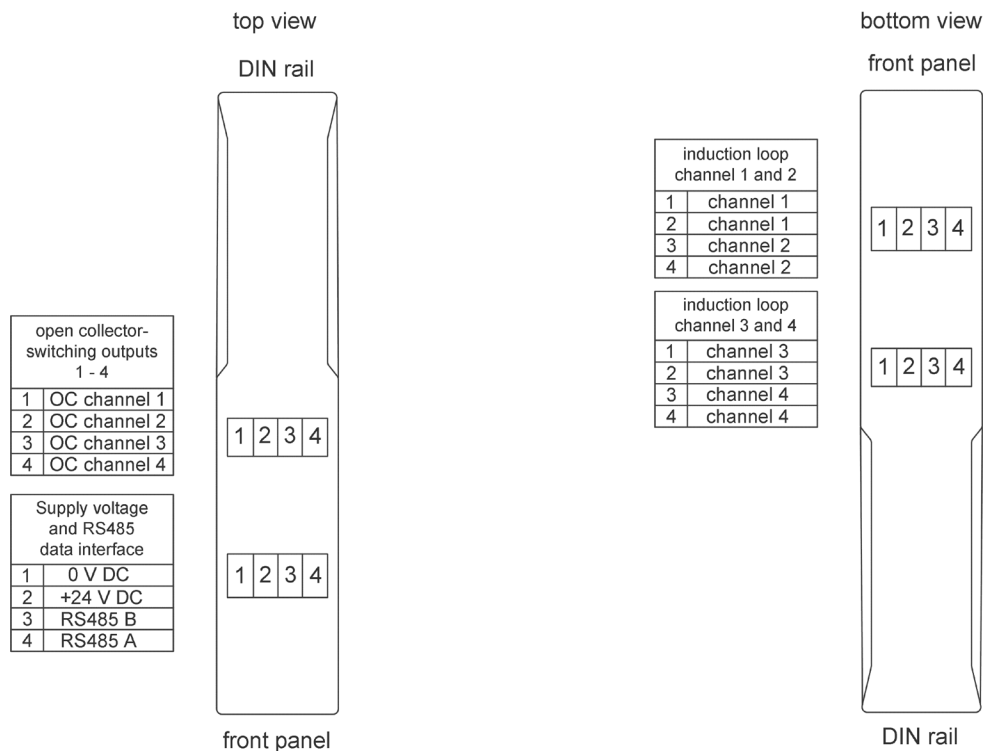

Figure 11: Pin assignment at the top and the bottom



NOTE

The terminals and connectors have a coding to prevent incorrect connections and thus a possible damage to the unit!

8.4.3 DIN-rail bus system TBUS

The TBUS bus system which can be integrated in the DIN-rail significantly reduces the effort for wiring several devices. With the bus system the synchronization lines, the RS485 data bus and the supply voltage (+ 24 V DC) can be comfortably through-wired. Doing so, the bus connection establishes “itself” within the device grid: snap the bus connector onto the DIN-rail – latch the module – finished.

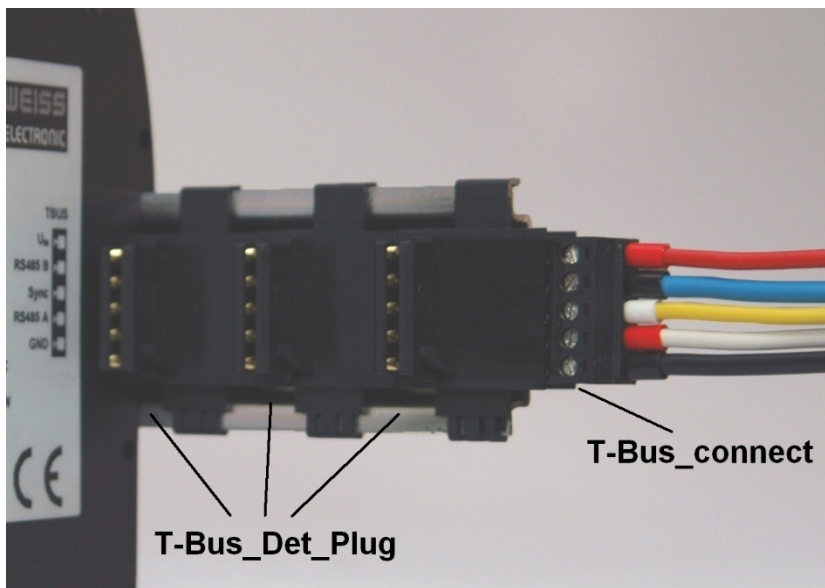

Figure 12: TBUS with bus connector and plug connector

The TBUS bus system includes the bus connectors and a plug connector at the right side where the RS485 data bus, the synchronization line (to external detectors) and the supply voltage can be connected:

- Bus connector, 5-pole, black, SWARCO TRAFFIC SYSTEMS GMBH article: T-BUS_Det_Plug (order no.:D.000.604.507)
- Plug with screw connection, 5-pole, black, Conductor cross section (flexible with conductor sleeve) 0.14 – 1.5 mm² (AWG 26 - 16), SWARCO TRAFFIC SYSTEMS GMBH article: T-BUS_connect (order no.: D.000.604.534)

Clamp no. / color Figure 12	Function
5 (top) / red	+ 24 V DC
4 / blue	RS485-B
3 / yellow	Synchronization
2 / white	RS485-A
1 (bottom)/ black	GND

Table 11: Pin assignment of the TBUS plug (front view)

Alternatively, for the connection at the TBUS at the side, the supply voltage and the RS485 data bus can also be connected via the 4-pole connecting plug at the front top of one device.

The connection of the synchronization with external detectors with identical synchronization method which are not connected with the TBUS can only be done via the plug T-BUS_connect at the side (max. length approx. 1 m). Doing so, the reference potentials GND of the supply voltages of the different detector types must also be connected with each other, if necessary.

8.4.4 Pin assignment service interface (3.5 mm stereo jack plug, TRS)



Figure 13: Pin assignment 3.5 mm jack plug

8.5 Requirements for the usage according to regulations

According to DIN EN 60950

The basic insulation of the device requires an exclusive connection of low voltage supply and switching voltages **below 60 V DC**. In addition, the power supplies used for the safe isolation must assure double or reinforced insulation between mains circuits and output voltage.

In compliance with the underlying pollution degree 2 the installation in an enclosure or control panel with at least IP54 is required.

If the device is to be exposed surges above the overvoltage category II, then additional surge protection has to be installed.

Requirements according to ETSI EN 300330-1

For the antenna factor (loop area A in m² multiplied by the number of loops turns N) applies:

$$N * A \leq 60 \text{ m}^2$$

The loop type to be used (ASTRA-SWISS) and the product class 2 (A < 30 m², N > 1) to be applied meet the requirements.

Installation of loops

For the installation of the inductive loops the regulations of ASTRA and the documentation "Loop Installation TLS" by SWARCO TRAFFIC SYSTEMS GMBH apply.

8.6 EC Conformity

EG-Konformitätserklärung EC-Declaration of Conformity

Hersteller / manufacturer: **Swarco Traffic Systems GmbH**

Adresse / address: **Niederkircher Str. 16**

54294 Trier

erklärt, dass das Produkt / declares that the product

Typ / type: **Klassifizierungsdetektor / Classification Detector**

Modell / model: **SW3224SP, SW3224T9**

Verwendungszweck / **Fahrzeugaufdeckung / vehicle detection**

bei bestimmungsmäßiger Verwendung den grundlegenden Anforderungen gemäß der EMV-Richtlinie 2014/30/EU entspricht und dass die folgenden Normen angewandt wurden:
complies with the essential requirements of the EMC Directive 2014/30/EU, if used for its intended use and that the following standards has been applied:

1 Sicherheit / Gesundheit
safety / health

Angewandte Norm(en) / Applied standard(s):	IEC 60950-1 EN 60950-1	2005 (2nd Edition)/A1:2009 2006/A11:2009/A1:2010
---	---------------------------	---

2 Elektromagnetische Verträglichkeit
electromagnetic compatibility

Angewandte Norm(en) / Applied standard(s):	ETSI EN 301 489-1 ETSI EN 301 489-3	V1.8.1 V1.4.1
---	--	------------------

3 Effiziente Nutzung des Funkfrequenzspektrums
efficient use of the radio frequency spectrum

Angewandte Norm(en) / Applied standard(s):	ETSI EN 300 330-1 ETSI EN 300 330-2	V1.7.1 V1.5.1
---	--	------------------

Trier, 07/02/20

(Ort und Datum der Konformitätserklärung)
(Place and date of the declaration of conformity)

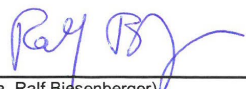

(ppa. Ralf Biessenberger)
(authorised officer)

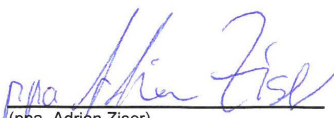

(ppa. Adrian Ziser)
(authorised officer)

032QM06

SWARCO TRAFFIC SYSTEMS GMBH
Niederkircher Straße 16
D-54294 Trier
www.swarco.com

© 2019 All rights reserved

Thank you for choosing a SWARCO TRAFFIC SYSTEMS GMBH quality product.